



PRINTtips



Graphics
Printing
Mailing
Under One Roof

TechneGraphics, Inc.
Park 50 TechCenter
2002 Ford Circle
Milford, OH 45150
(513) 248-2121
Fax (513) 248-5141

Web site:
www.techgra.com

File Transfer site:
www.tgidirect.net

FTP site:
<ftp.techgra.com>

Email:
info@techgra.com

Would you like more tips?

Try our weekly email newsletter – Tuesday Tips. To be added to the mailing list, send a request to:
info@techgra.com

Design That Communicates

Whether your task is to design a sales brochure, a display ad, or a newsletter, the purpose is the same: to communicate a message to an audience and to produce a desired response. Put simply, you want to say something to someone so that the person takes a specific action. What this means is that the design you develop is not just about appearance – it is also about the performance of the target audience. Thus good design is measured equally by form and function.

In *The Desktop Publisher's Idea Book*, Chuck Green describes five steps that form the basis of good design:

- *Set the goal*
- *Compose the message*
- *Choose the medium*
- *Select a design*
- *Illustrate the message*

Set the goal

Every design task begins by defining the end to be achieved – in other words, the goal of the design project. The goal is most often related to the action desired by the target audience. Is the purpose to invite an inquiry? To generate a purchase? To persuade the reader to a new point of view? Keep the goal in mind and allow it to inform the design.

Compose the message

The message is the most important element of any marketing piece, for it informs the reader of the benefits of taking action. Affecting behavior is the result of explaining to the reader what to



expect from the product or service – or stated differently, answering the reader's question, *What's in it for me?*

If you have a limited amount of space, devote most of it to benefits. Leave the list of features and the company story off altogether, or include it in abbreviated form. Make the message reader-centered and clearly describe the enjoyment the reader will experience or the pain that will be relieved.

Choose the medium

The project's purpose and message both inform the layout. Sometimes the layout will be obvious – a business card, for example, or a display ad. Other times the choices will be broader. A flyer, a brochure or a self-mailer are all viable for a marketing piece; the ultimate choice might be determined by the method of delivery to the target audience (for example, via direct mail, at a trade show, or mailed in response to an inquiry).

Select a design

To achieve maximum effectiveness, a design must take into account a myriad of elements related to the target audience. Some of these elements are

Design That Communicates (continued)

age, education, language skills, visual preferences, cultural expectations, level of knowledge, and desires. These and other factors affect the selection of color palette, fonts, illustrations, and photographs.

“... draw attention to a specific element of the design.”

Illustrate the message

Photographs and illustrations work the hardest when they reiterate and reinforce the message or show what can't be said. Secondary use is to set the tone or draw attention to a specific element of the design. It is always desirable when a photograph or illustration can do both simultaneously.

Clip art collections are a convenient and economical way to find an appropriate illustration and many can be found on the Worldwide Web. However, we offer a word of caution about sites offering free clip art: read the Terms of Use carefully. Clip art that is in the public domain (and therefore free) has no restrictions on use. Look especially for a condition that limits use to personal applications, meaning the image cannot be used in a business application such as a brochure. Also be aware that much clip art is intended for use on web sites which may make the resolution too low for commercial printing.

If you need some photographs or illustrations for your layout, call us at 513-248-2121. We may have something suitable in our collection of stock photography.

The four basic principles of design

A good design is built using four principles: alignment, proximity, contrast, and repetition. The four are interconnected and work together to communicate the message.

Alignment

Alignment refers to how text and graphics are placed on the page. Alignment creates order, organizes page elements, indicates groups of items, and emphasizes visual connection. Interestingly, good alignment is rarely noticed by the reader, while misalignment is immediately detected.

“...direct the reader around the page...”

There are two basic types of alignment: edge and center. Edges can be aligned along the top, bottom, left or right. Center alignment can be either horizontal or vertical. When designing a page, be sure that each element (text, graphics, photograph) has a visual alignment with another item.

Proximity

Proximity describes the distance between individual design elements. Close proximity implies a relationship between the elements; conversely, lack of proximity separates them.

Like alignment, proximity is a tool of visual organization. Placing elements in close proximity unifies them and communicates a sense of order and organization to the reader. When it isn't possible to group items proximately, then achieve unity between two elements by using a third element to connect them.

Contrast

Contrast adds interest as well as organization to the page and is created when two elements are different. Common ways to create contrast include varying size, color, thickness, shape, style, or space. The greater the difference between elements, the greater the contrast.

Besides adding interest to the page, contrast can be used to direct the reader around the page and to emphasize importance or differences. Contrast is only effective when it is evident.

Repetition

Repetition brings visual consistency to page design. When the same design elements – such as uniform size and weight of headline fonts or use of initial caps to begin a chapter – are used, it becomes clear that the pages are related to each other and therefore part of the same document. In this way, repetition creates unity.

Some examples of repetition are using the same style of headlines, the same style of initial capitals, or repeating the same basic layout from one page to another.

Simple Layout Trick

Trying to lay out a grid for your design and getting stuck in complicated mathematics? Use this simple trick with your ruler and you will be able to divide almost any dimension by any number.

Let's say you want to divide an 11" sheet of paper into thirds. Dividing 11 by 3 is a difficult calculation in your head, and converting decimals to the fractions you need to measure is also tricky. So instead, just lay the ruler on an angle on the sheet of paper, as shown in the illustration, so that the 0" and 12" marks of the ruler are at the edge of the sheet. Now divide 12 by 3 – a nice, easy 4. Mark the paper at the 4" and 8" divisions on the ruler, then draw a line at the dot,

perpendicular to the top and bottom edge of the sheet of paper. Presto – your thirds are created.

The finer the divisions on your ruler, the more difficult division tasks you can perform. Try it and see.

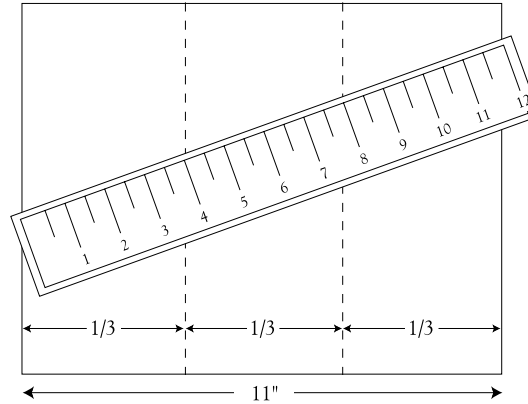

“... just lay the ruler on an angle on the sheet of paper...”

Q. *I need to plan a design. Can you give me any tips to get started?*

A. Begin with the end in mind – decide whom you want to reach and what you want them to learn or do. Try using these check questions to organize your thoughts.

1. Who is the target audience?
2. What must this creative design accomplish?
3. Are there any perceptions of the target audience that must be created or overcome?
4. What is the single most important message the target audience should take away from this design?
5. What is the overall or primary benefit to the target audience?
6. What tone should be conveyed to the target audience?
7. What elements or information must be included in this design?



“Begin with the end in mind...”

Please Route to the Printing Buyer

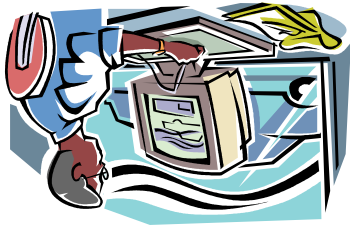

**Design That
Communicates**

June 2008 PRINTtips

Additional Design Tips

Other tips for creating good design include:

- *Be spare and simple.* Carefully select the design elements so a few will convey the message, as a design cluttered with too many elements may confuse or overwhelm the reader. For example, use one large photograph or graphic on a page rather than several smaller ones. And use lots of white space – studies show that designs with significant white space are more pleasant to read and get attention.
- *Use color sparingly.* As a design element, color is very important, though too much color can be counterproductive. Use a consistent color palette and use contrasting color sparingly so that its impact is increased.

- *Limit the selection of fonts.* Select one typeface and size for body copy and one typeface for headlines, then use these throughout your design. Using too many fonts can be distracting and may interfere with page organization.
- *Write clean, comprehensible copy.* Remember that a good design effectively conveys a message. Write in short rather than long sentences. Avoid jargon and clichés. Use a vocabulary level appropriate for the audience you are trying to reach.

By paying close attention to the four basic principles of design and the additional tips, you will ensure that you create design that communicates.